

INTERCOM SYSTEM USER MANUAL

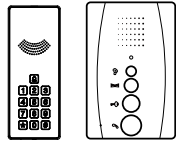

ON-3201AD

CE
Version 1.0

What's Included

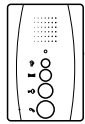

Indoor Unit
*1

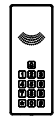

Outdoor Unit
*1

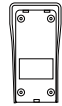

Rain shade
*1



Screw Pack
*1

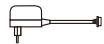

Adapter
*2

Features

- Password unlock.
- Unlock via the indoor unit.
- An exit button can be connected to unlock.
- Key press tone, keypad back light (blue) design.
- Monitor/listen the outdoor unit.
- Hands-free intercom.

1

Installation Instruction

A. Indoor unit installation

1. Place the unit against the wall and then mark the hole locations on the wall, through which the mounting screws will be threaded.

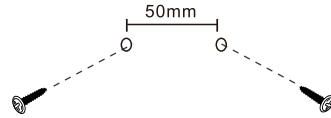

2. Connect the wires according to the wiring diagram.
3. Connection to power source.
4. Hang the unit onto the mounting screws.

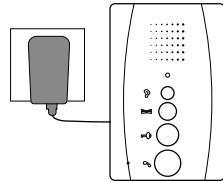

B. Outdoor unit installation

1. Fasten the rain shade on the wall with screws. (1.4-1.6m high from the ground, Screw size: 4*40BA)

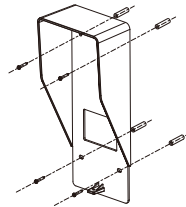

2. Connect the wires according to the wiring diagram.
3. Fix into the rain shade and fasten the bottom with screws.

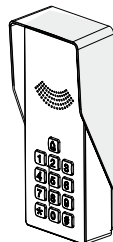

2

Wiring Diagram

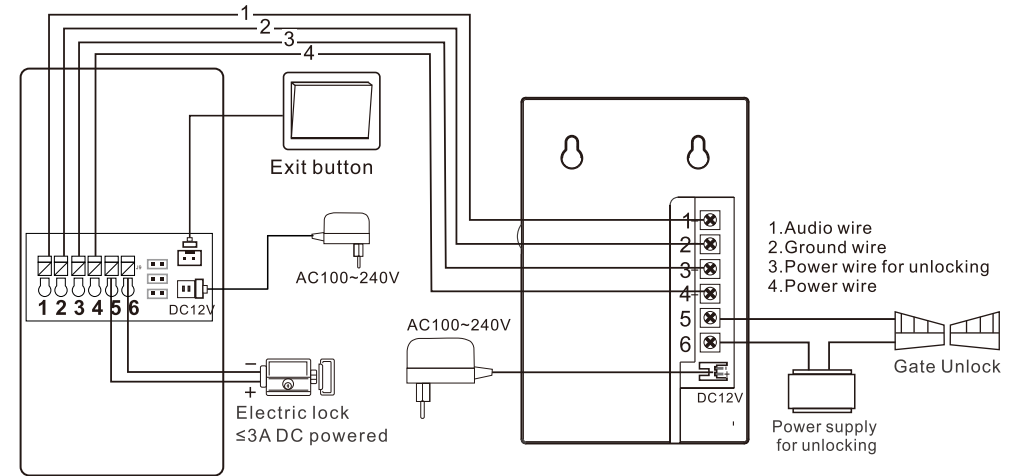

How to attach wires to terminals

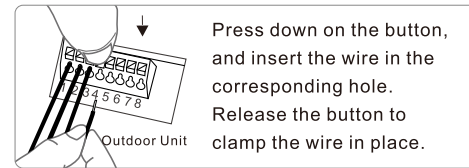

- When connecting, terminals 1/2/3/4 on the outdoor unit to terminals 1/2/3/4 on the indoor unit;
- If the distance is <15m, use the RVV4×0.3 mm² cable.
- If the distance is <50m, use the RVV4×0.5 mm² cable.

- When connecting the gate lock, if the distance is <15m, use the RVV2×1.0 mm² cable.

Note:

Before pressing the Gate Unlock button, terminals (5/6 on the indoor unit) are in the "Normally Open" state. When pressing down the button, terminals are "shorted and connected". The terminals are used to connect the electric lock that works in <30V, <3A (AC or DC), and additional power supply for the lock to work is required.

Operation Instruction

Indoor unit

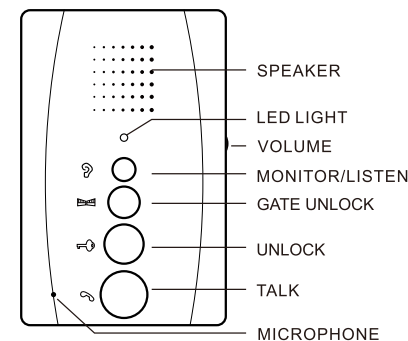

3

1. Calling from the outdoor unit

When the visitor presses the CALL button on the outdoor unit, the indoor unit will ring. Press() on the indoor unit to talk with the visitor. During the communication, press() to unlock and press again () to end the communication.

NOTE:

The talking time is 120s. Once the time elapsed, it will hang up automatically.

2. Monitor/Listen the outdoor unit

Press() on the indoor unit to listen the audio transmitted from the outdoor unit. Press it again to exit.

3. Unlocking

In monitor/calling/talking status,

Press the **UNLOCK button**() to release the electric lock.

Press the **GATE UNLOCK button** () to release the outdoor gate lock

4

Outdoor unit

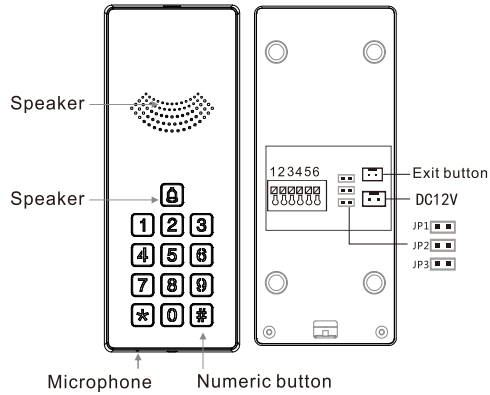

◆ Description of indicator sounds:

- Two "Di" sounds: next step
- Five continuous "Di" sounds: operation error or timeout exit.
- A long "Di" sound: operation succeed

◆ Unlocking via entering user passwords on the outdoor unit

In standby state, enter the user password + "*" to unlock. By default, both the 01 user password and administrator password are 123456. For security, please change them immediately.

◆ User password setting

The outdoor unit supports 9 user passwords to be set. The setting method as follows:
In standby state, press "*" button, it sounds two "Di" tones. Then, enter the administrator password + "#", it sounds two "Di" tones. Then, press "1" to enter into user password setting state, it sounds two "Di" tones. Now if you want to create the 01 user password for example, enter "01", it sounds two "Di" tones. Then, enter the new user password + "#", it sounds two "Di" tones. Enter the new user password + "*" again, a long "Di" tone will be given to indicate the setting is successful. Press "*" button to exit.

NOTE:

- To create other user passwords, simply follow the instructions above.
- If timed out, press "*" to exit first and then try again.
- If user passwords are lost, follow the instructions above to set the new ones. The old passwords will be replaced by the new ones.

◆ Administrator password setting

The administrator password is only used to enter system settings. It cannot be used to unlock.

To change the administrator password, follow the instructions below:

In standby state, press "*" button, it sounds two "Di" tones. Then, enter the current administrator password + "#", it sounds two "Di" tones. Then, press "2" to enter into administrator password setting state, it sounds two "Di" tones. Now, if you want to change the administrator password, enter the new administrator password + "#", it sounds two "Di" tones. Enter the new administrator password + "*" again, a long "Di" tone will be given to indicate the setting is successful. Press "*" button to exit.

If the administrator password is lost, follow the instructions below to initiate it.

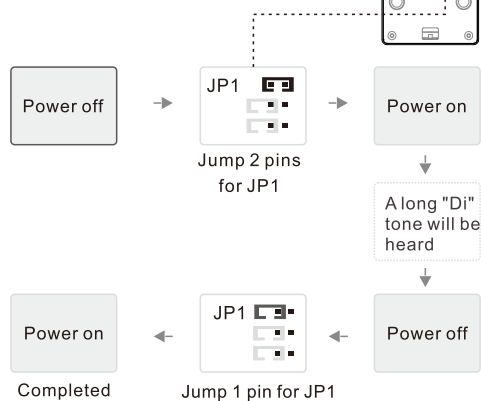

NOTE:

- After initiation
- The administrator password will be reset to 123456 or 1234.
 - System will clear all the user passwords. To create user passwords, refer to the section "User password setting".

◆ Password length setting

Switch to 4-digit password (1234 by default)

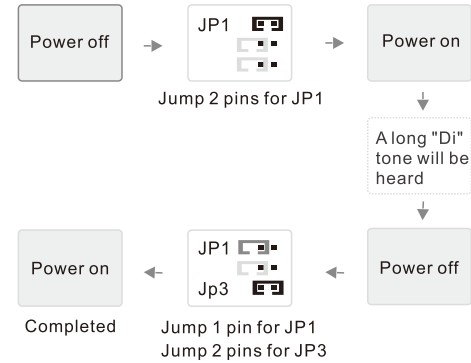

Switch to 6-digit password (123456 by default)

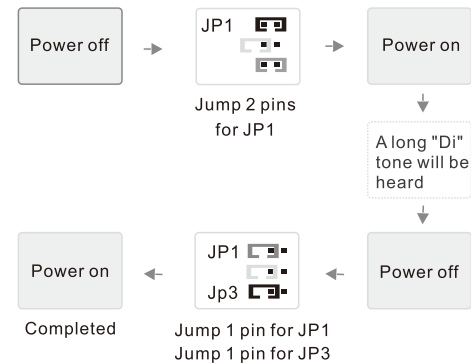

◆ Unlock time setting

- Turn off the power, for JP2, insert the jumper cap to 2 pins and then turn on the power. It will set the unlock time to 5 seconds.
- When removing the jumper cap, it will set the unlock time to 3 second.



Specifications

Indoor Unit

Power	DC12V 1A
Power Consumption	Static State <20mA Working State <220mA
Melody Volume	≥70dB

Outdoor Unit

Power	DC12V 1A
Power Consumption	Static State <60mA Working State <80mA
Installation	Surface mounted
Guest password	9 groups
Outline dimension	198.8(h) * 86(w) * 50.8(d)mm
Operating Temperature	-10°C ~ 40°C
Operating Humidity	10%~90%(RH)

NOTICES

- Turn off the power before wiring.
- If the product doesn't work after installation, check if wires are connected properly and securely.
- If it is unable to unlock, check if wires are connected properly and securely. Also, make sure the voltage received for unlocking is sufficient.